

BALDOR® • RELIANCE 

Product Information Packet

VEWDM3611T

3HP, 1760RPM, 3PH, 60HZ, 182TC, 3632M, TEFC, F1

Part Detail							
Revision:	N	Status:	PRD/A	Change #:		Proprietary:	No
Type:	AC	Elec. Spec:	36WGS266	CD Diagram:	CD0005	Mfg Plant:	
Mech. Spec:	36K187	Layout:	36LYK187	Poles:	04	Created Date:	06-29-2011
Base:	N	Eff. Date:	09-13-2017	Leads:	9#16		

Specs			
Catalog Number:	VEWDM3611T	Heater Indicator:	No Heater
Enclosure:	TEFC	Insulation Class:	F
Frame:	182TC	Inverter Code:	Inverter Ready
Frame Material:	Steel	KVA Code:	K
Output @ Frequency:	3.000 HP @ 60 HZ	Lifting Lugs:	No Lifting Lugs
Synchronous Speed @ Frequency:	1800 RPM @ 60 HZ	Locked Bearing Indicator:	Locked Bearing
Voltage @ Frequency:	460.0 V @ 60 HZ	Motor Lead Quantity/Wire Size:	9 @ 16 AWG
	230.0 V @ 60 HZ	Motor Lead Exit:	Ko Box
XP Class and Group:	None	Motor Lead Termination:	Flying Leads
XP Division:	Not Applicable	Motor Type:	3632M
Agency Approvals:	UR	Mounting Arrangement:	F1
	CSA EEV	Power Factor:	75
	CSA	Product Family:	Wash Down
Auxillary Box:	No Auxillary Box	Pulley End Bearing Type:	Ball
Auxillary Box Lead Termination:	None	Pulley Face Code:	C-Face
Base Indicator:	No Mounting	Pulley Shaft Indicator:	Standard
Bearing Grease Type:	Polyrex EM (-20F +300F)	Rodent Screen:	None
Blower:	None	Shaft Extension Location:	Pulley End

Current @ Voltage:	4.200 A @ 460.0 V	Shaft Ground Indicator:	No Shaft Grounding
	8.400 A @ 230.0 V	Shaft Rotation:	Reversible
	9.000 A @ 208.0 V	Shaft Slinger Indicator:	Shaft Slinger
Design Code:	B	Speed Code:	Single Speed
Drip Cover:	No Drip Cover	Motor Standards:	NEMA
Duty Rating:	CONT	Starting Method:	Direct on line
Electrically Isolated Bearing:	Not Electrically Isolated	Thermal Device - Bearing:	None
Feedback Device:	NO FEEDBACK	Thermal Device - Winding:	None
Front Face Code:	Standard	Vibration Sensor Indicator:	No Vibration Sensor
Front Shaft Indicator:	None	Winding Thermal 1:	None
		Winding Thermal 2:	None

Nameplate NP1669L										
CAT.NO.	VEWDM3611T									
SPEC.	36K187S266G1									
HP	3									
VOLTS	230/460									
AMP	8.4/4.2									
RPM	1760									
FRAME	182TC				HZ	60			PH	3
SER.F.	1.15		CODE	K	DES	B		CLASS	F	
NEMA-NOM-EFF	89.5		PF	75						
RATING	40C AMB-CONT									
CC	010A				USABLE AT 208V					9
DE	6206				ODE	6205				
ENCL	TEFC			SN						
BLANK										

Parts List		
Part Number	Description	Quantity
SA226400	SA 36K187S266G1	1.000 EA
RA213498	RA 36K187S266G1	1.000 EA
36FN3000C01SP	EXFN, PLASTIC, 5.25 OD, .912 ID	1.000 EA
36CB3005A03W	36 CB .75 NPT @ 6 W/WHITE EPOXY	1.000 EA
35GS1040	35 MOLDED GASKET W/LIP, LEAD SEAL,	1.000 EA
51XB1016A08	10-16X 1/2HXWSSLD SERTYB	2.000 EA
11XW1032G06	10-32 X .38, TAPTITE II, HEX WSHR SLTD U	1.000 EA
36EP3104A03MW	FREP MACH (RAISED FH PADS) WHITE EPOXY	1.000 EA
HW4032A01	BLACK DRAIN PLUG FOR WASH DOWN MOTORS	3.000 EA
HW5100A05	WVY WSHR F/205 & 304 BRGS	1.000 EA
36PE3301A27MW	PUEP ASSEMBLY FOR ROUTING PURPOSES	1.000 EA
HW4032A01	BLACK DRAIN PLUG FOR WASH DOWN MOTORS	3.000 EA
HW4600B50	SEAL 1.156 X 1.874 X 0.250 SINGLE LIP DB	1.000 EA
10XN2520S26	1/4-20X 1 5/8 HEX HD SS	4.000 EA
36FH4010A08	IEC FH NO GREASER - W/PRIMER	1.000 EA
11XW1032S06	10-32 X .38, TAPTITE II, HEX WSHR SLTD U	3.000 EA
HA1005A03SP	SLINGER, OD 1.750, ID .938, 205 BRG	1.000 EA
HW4600B36SP	V-RING SLINGER 1.188 X 1.690 X .24 VITON	1.000 EA
36CB4518	36 LIPPED CB LID PRIMED	1.000 EA
37GS3010SP	1/16"WHITE LID GASKET	1.000 EA
59XW0832S07	TAPTITE II,HEX WSHR UNSLTD SER,410 S.S.,	4.000 EA
HW2502E16	#303 SS,SQ KEY 1/4 X 1.750	1.000 EA
HA7000A02	KEY RETAINER RING, 1 1/8 DIA, 1 3/8 DIA	1.000 EA
HA5027A01	HA4066A01 T-DRAIN X2 BAGGED	1.000 EA

Parts List (continued)		
Part Number	Description	Quantity
MJ5001A27	32220KN GRAY SEALER *MIN BUY 4 QTS=1GAL	0.001 QT
LB1164	LABEL,WARNING AND DRAIN	1.000 EA
85XU0407S04	4X1/4 U DRIVE PIN STAINLESS	2.000 EA
MJ1000A02	GREASE, MOBIL POLYREX EM - 124047	0.050 LB
51XB1214A16	12-14X1.00 HXWSSLD SERTYB	1.000 EA
MG1025Z02	ACTIVATOR WILKOFAS 060.02HF	0.010 GA
MG1025W01	WILKOFAS 781.01, SIGNAL WHITE #9003	0.022 GA
HA3101S25	THRUBOLT- 1/4-20 X 11.00 X	4.000 EA
LC0005	CONN.DIA.,TY M,9-LD,DUAL VOLT,REVERSING	1.000 EA
NP1669L	SS WD SUPER-E UL CSA-EEV PREM REV MTG	1.000 EA
36PA1000	PKG GRP, PRINT PK1016A06	1.000 EA
PK3082	STYROFOAM CRADLE	1.000 EA
MN416A01	TAG-INSTAL-MAINT no wire (1200/bx) 3/19	1.000 EA
FE-0000001	ZRTG FE ASSEMBLY	1.000 EA

AC Induction Motor Performance Data

Record # 53364 - Typical performance - not guaranteed values

Winding: 36WGS266-R006	Type: 3632M	Enclosure: TEFC
-------------------------------	--------------------	------------------------

Nameplate Data				460 V, 60 Hz: High Voltage Connection	
Rated Output (HP)	3			Full Load Torque	8.8 LB-FT
Volts	230/460			Start Configuration	direct on line
Full Load Amps	8.4/4.2			Breakdown Torque	37.6 LB-FT
R.P.M.	1760			Pull-up Torque	15.2 LB-FT
Hz	60	Phase	3	Locked-rotor Torque	21.7 LB-FT
NEMA Design Code	B	KVA Code	K	Starting Current	32.7 A
Service Factor (S.F.)	1.15			No-load Current	2.3 A
NEMA Nom. Eff.	89.5	Power Factor	75	Line-line Res. @ 25°C	3.81 Ω
Rating - Duty	40C AMB-CONT			Temp. Rise @ Rated Load	44°C
S.F. Amps				Temp. Rise @ S.F. Load	52°C
				Locked-rotor Power Factor	42.2
				Rotor inertia	0.298 LB-FT ²

Load Characteristics 460 V, 60 Hz, 3 HP

% of Rated Load	25	50	75	100	125	150	S.F.
Power Factor	35	55	68	75	80	82	77
Efficiency	81.1	87.8	89.6	89.8	89.7	88.2	89.2
Speed	1791	1783	1773	1764	1753	1741	1754
Line amperes	2.47	2.85	3.43	4.09	4.89	5.78	4.63

Performance Graph at 460V, 60Hz, 3.0HP Typical performance - Not guaranteed values

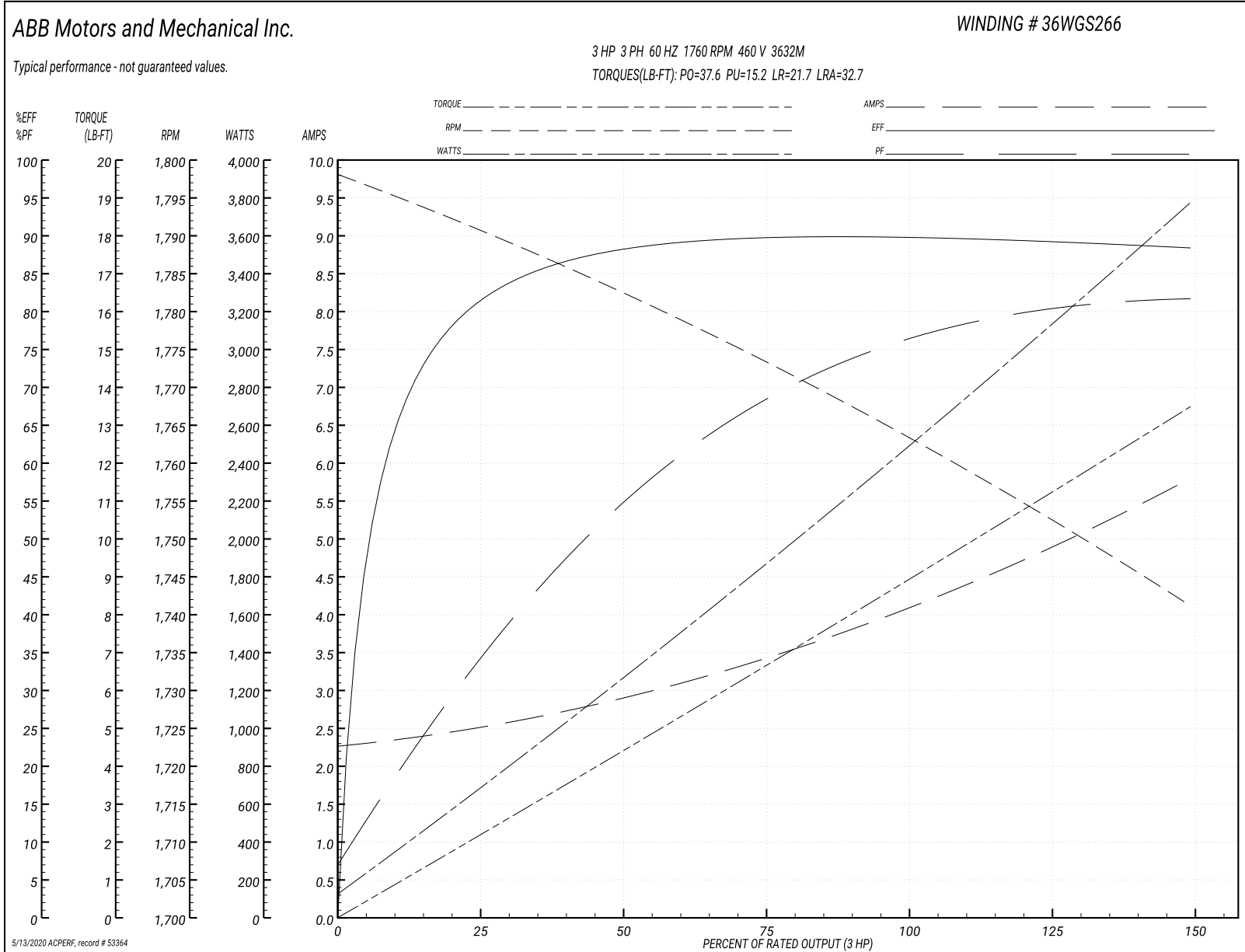

AC Induction Motor Performance Data

Record # 57957 - Typical performance - not guaranteed values

Winding: 36WGS266-R006	Type: 3632M	Enclosure: TEFC
-------------------------------	--------------------	------------------------

Nameplate Data				230 V, 60 Hz: Low Voltage Connection	
Rated Output (HP)	3			Full Load Torque	8.8 LB-FT
Volts	230/460			Start Configuration	direct on line
Full Load Amps	8.4/4.2			Breakdown Torque	37.6 LB-FT
R.P.M.	1760			Pull-up Torque	15.2 LB-FT
Hz	60	Phase	3	Locked-rotor Torque	21.7 LB-FT
NEMA Design Code	B	KVA Code	K	Starting Current	65.4 A
Service Factor (S.F.)	1.15			No-load Current	4.6 A
NEMA Nom. Eff.	89.5	Power Factor	75	Line-line Res. @ 25°C	0.953 Ω
Rating - Duty	40C AMB-CONT			Temp. Rise @ Rated Load	44°C
S.F. Amps				Temp. Rise @ S.F. Load	52°C
				Locked-rotor Power Factor	42.2
				Rotor inertia	0.298 LB-FT ²

Load Characteristics 230 V, 60 Hz, 3 HP

% of Rated Load	25	50	75	100	125	150	S.F.
Power Factor	35	55	68	75	80	82	78
Efficiency	81.1	87.8	89.6	89.8	89.7	88.2	89.7
Speed	1791	1783	1773	1764	1753	1741	1757
Line amperes	4.94	5.7	6.86	8.18	9.78	11.6	9.14

Performance Graph at 230V, 60Hz, 3.0HP Typical performance - Not guaranteed values

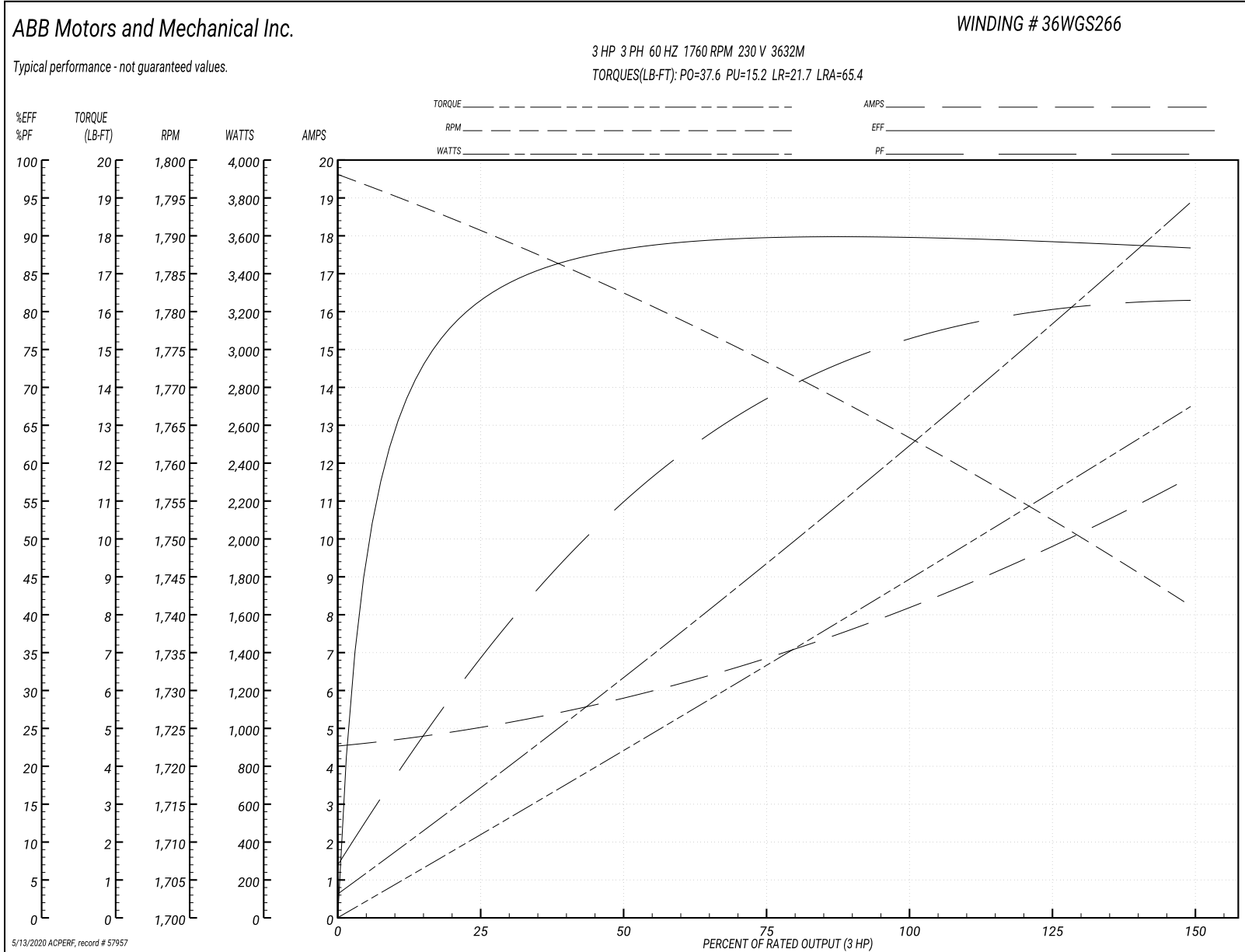

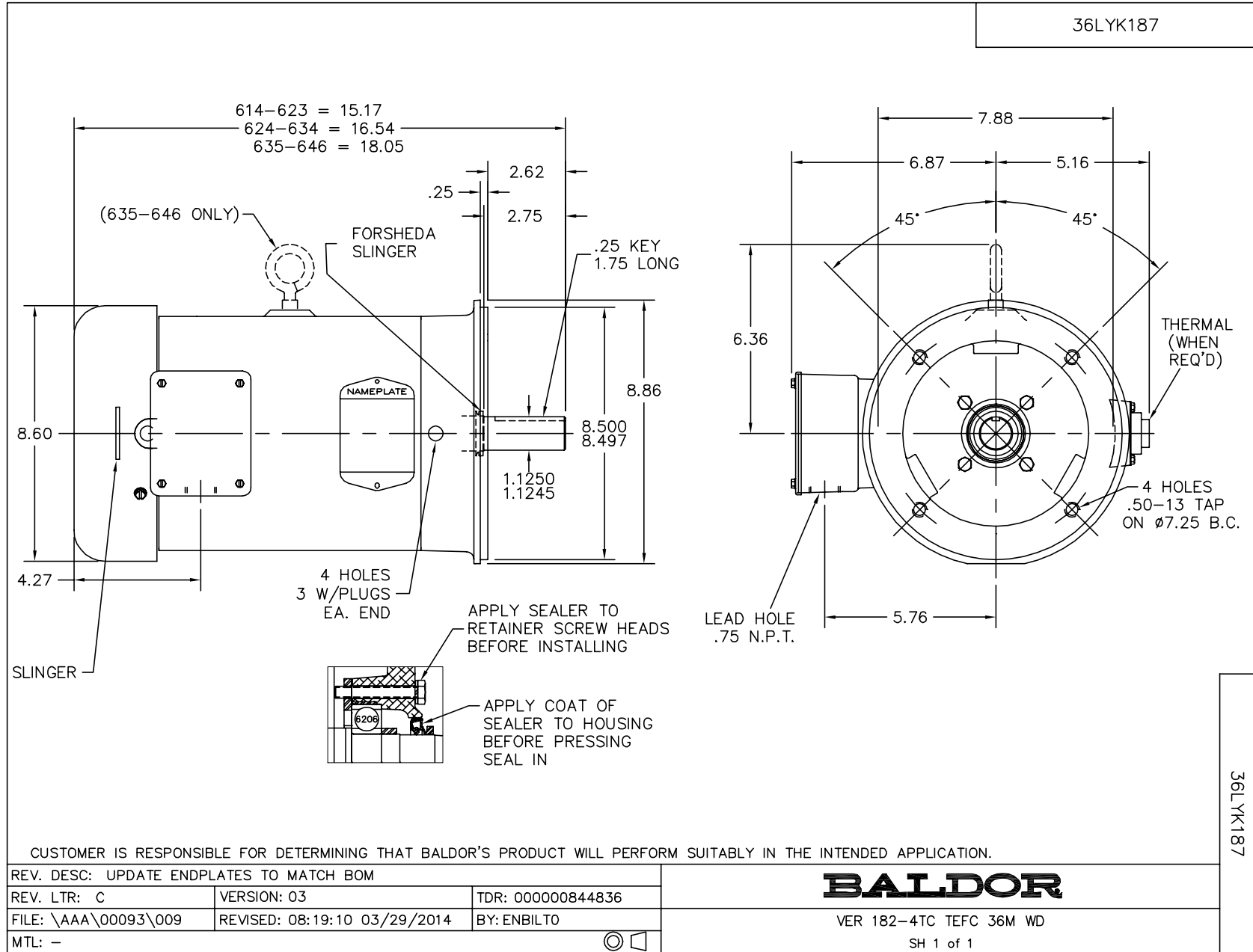

CD0005

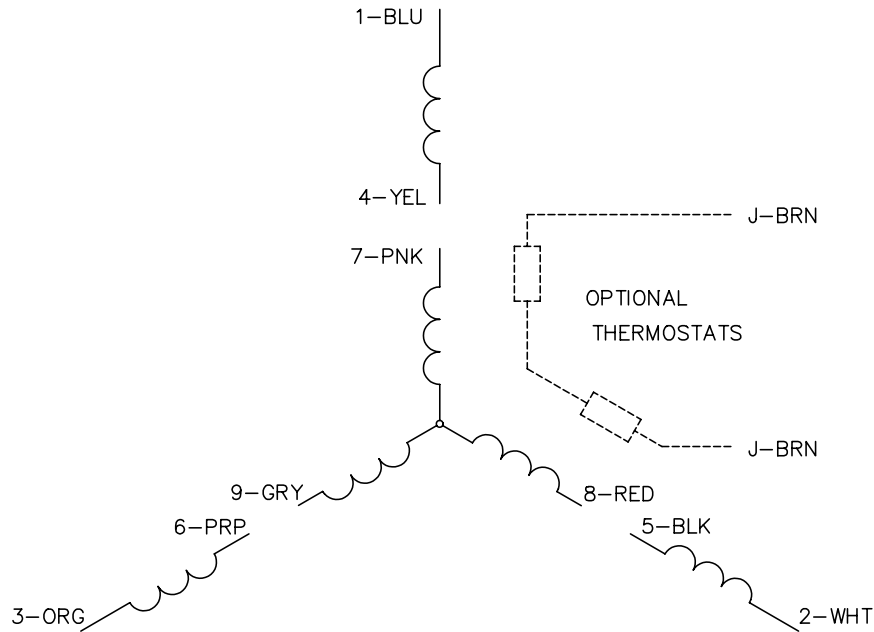

LOW VOLTAGE
(2Y)

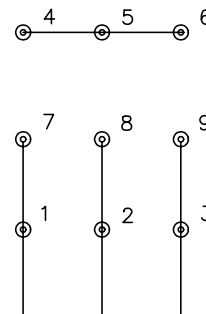

LINE

HIGH VOLTAGE
(1Y)

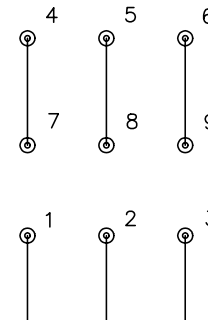

LINE

NOTES:

1. INTERCHANGE ANY TWO LINE LEADS TO REVERSE ROTATION.
2. OPTIONAL THERMOSTATS ARE PROVIDED WHEN SPECIFIED.
3. ACTUAL NUMBER OF INTERNAL PARALLEL CIRCUITS MAY BE A MULTIPLE OF THOSE SHOWN ABOVE.
4. LEAD COLORS ARE OPTIONAL. LEADS MUST ALWAYS BE NUMBERED AS SHOWN.

REV. DESC: REVISE TO SHOW OPTIONAL COLORS			
REV. LTR: E	BY: JLP	REVISED: 01/19/99 10:15	TDR: 0171435
900000		FILE: AAA00005140	MDL: -
		MTL: -	

BALDOR ELECTRIC Co.

3PH, DV, 9 LEADS

CD0005